

## Journal Pre-proof

Influence of high pressure compaction on solubility and intrinsic dissolution of ibuprofen binary mixtures employing standard excipients

Bashar Ibraheem, Karl G. Wagner



PII: S2590-1567(21)00004-9

DOI: <https://doi.org/10.1016/j.ijpx.2021.100075>

Reference: IJPX 100075

To appear in:

Received date: 10 March 2021

Accepted date: 11 March 2021

Please cite this article as: B. Ibraheem and K.G. Wagner, Influence of high pressure compaction on solubility and intrinsic dissolution of ibuprofen binary mixtures employing standard excipients, (2021), <https://doi.org/10.1016/j.ijpx.2021.100075>

This is a PDF file of an article that has undergone enhancements after acceptance, such as the addition of a cover page and metadata, and formatting for readability, but it is not yet the definitive version of record. This version will undergo additional copyediting, typesetting and review before it is published in its final form, but we are providing this version to give early visibility of the article. Please note that, during the production process, errors may be discovered which could affect the content, and all legal disclaimers that apply to the journal pertain.

© 2021 Published by Elsevier.

## Influence of high pressure compaction on solubility and intrinsic dissolution of ibuprofen binary mixtures employing standard excipients

Bashar Ibraheem ph\_bashar@uni-bonn.de, Karl G. Wagner, Prof. Dr karl.wagner@uni-bonn.de

Department of Pharmaceutical Technology and Biopharmaceutics University of Bonn Bonn, Germany

\*Corresponding author.

### Abstract

Enabling formulations often depend on functional excipients. However, the question remains whether excipients regarded as standard establish similar interactions and subsequently improvement of solubility when employed at unusual manufacturing process conditions. In this study, compaction of API under high pressure in the presence of hydrophilic excipients is proposed as a technique to improve the solubility and/or dissolution rate with an acceptable preservation of the supersaturation state. Binary mixtures of ibuprofen (IBU) with hydroxypropyl cellulose, isomalt, mannitol and sorbitol were compacted applying high pressure (500 MPa) with and without a previous co-milling step. Intrinsic dissolution rate (IDR) was selected to characterize and evaluate dissolution performance. The IDR of neat IBU increased from 5 to 88 fold and the aqueous solubility in the range of 3 to 54%. Regarding the polyols isomalt showed the highest impact on solubility and dissolution, without changing the crystallinity of IBU independent of a co-milling step. Even higher impact was achieved in combination with HPC. However, only without a previous co-milling step, ibuprofen remained crystalline, while co-milling induced an amorphous IBU-content of 38%. Based on XRPD and DSC findings, higher IDR and solubility values correlated with crystal modifications as well as IBU/excipient interactions.

**Keywords:** Solubility enhancement; intrinsic dissolution; high-pressure compaction; drug/excipient interactions; hydrophilic excipients; crystal modification

### Abbreviations:

API, active pharmaceutical ingredient; ASD, amorphous solid dispersion; BCS, biopharmaceutics classification system; COM, co-milled; Cs, aqueous solubility; DSC, differential scanning calorimetry; Gr, granules; HCL, hydrochloric acid; HPC, hydroxypropylcellulose; HPC-SSL, super special-low viscosity hydroxypropylcellulose; IBU, ibuprofen; IDR, intrinsic dissolution rate; ISO, isomalt; MANN, mannitol; MIX, mixtures; MUPS, multiple unit pellet system; PM, physical mixtures; SFE, surface free energy; SORB, sorbitol; ST, standard; Tab, tablets; Tg, glass transition temperature; Tm, melting point; XRPD, X-ray powder diffraction

## 1 Introduction

The increasing number of new drug candidates exhibiting poor solubility and dissolution properties within the past decade, resulted in various enabling principles to overcome the poor aqueous solubility and thereby potentially increase their bioavailability (Buckley et al., 2013; Fahr and Liu, 2007). Among the various available approaches of enabling formulations, which include the use of nanosuspension,

complexation, non-ionic surfactants, liposomal formulations, and self-emulsifying drug delivery systems (Bindu MB et al., 2010; Fahr and Liu, 2007; Khadka et al., 2014; Rasenack and Müller, 2005a, 2005b; Singh et al., 2011; Vemula et al., 2010), the formation of amorphous solid dispersions (**ASDs**) is, however, of pronounced interest, where insoluble drugs are dissolved in soluble solid hydrophilic carrier or matrices at solid state (Leuner and Dressman, 2000). In spite of their proven ability to improve solubility and form a supersaturated state, these systems are often associated with limited stability (Rasenack and Müller, 2005b), which may counteract their benefits, beside potential precipitation, considering that the maintenance of supersaturation in the gastro-intestinal pH-range is a critical factor to govern the bioavailability (Zecevic et al., 2014). In addition, the preparation of ASD is often time-consuming, involving multiple steps. Hence, the selection of an enabling technology needs to balance bioavailability over stability and manufacturing aspects, especially in case of borderline solubility-limited drug candidates in between Biopharmaceutics Classification System **BCS** I and II or III and IV, respectively. Interactions between active pharmaceutical ingredients (**API**) and functional excipients are often employed to improve solubility and dissolution kinetics in enabling formulations (Thakkar et al., 2016). However, the question remains whether excipients regarded as standard might establish similar interactions; subsequently, improvement of aqueous solubility when employed at unusual manufacturing process conditions. For us, the potential on wettability and aqueous solubility by compacting API and hydrophilic excipients at high pressure, as could be performed via briquetting in a tablet machine for small scale (Pitt and Sinka, 2007; Sill et al., 2009) or in a roller compaction process for larger scale, was of special interest.

The strategy was based on compaction of binary mixtures; consisting of a crystalline drug and a water-soluble standard excipient that has polar groups such as polyols, or polymers like polyvinylpyrrolidone, hydroxypropyl cellulose, through application of high compression pressure.

The approach involves the application of high mechanical energy that is capable to physically breaks down particles, and can defect the crystal lattice of each single ingredient, similar to the impact obtained by grinding process (Loh et al., 2015). This might generate crystal modification, which is manifested either in new crystal habits, crystal defects, metastable polymorphic forms or a decrease in the degree of crystallinity, creating activated surfaces of elevated energy, i.e. improved solubility. The disordered structure, which is induced by disordering the position of atoms or molecules within the crystal (mechanochemical activation) (Loh et al., 2015; Rasenack and Müller, 2005c), would lead to higher thermodynamic activity, resulting in faster dissolution behavior. Chan *et al.* referred, that upon compaction, crystal energetics can be altered by changing the nature, concentration (density) and profile of the crystal defects (Chan and Grant, 1989). Thus, disc- intrinsic dissolution rate (**IDR**) might deviate from the corresponding crystal-IDR.

In the current study, direct compression was applied as a functional tool to produce the desired formulations. The problem caused by tablet compression at very high pressure, however, is usually a prolongation of disintegration process. Hence, these compacts should be regarded as granules produced via briquetting. These granules would form multiparticulate tablets, where the dense granules could be dispersed in a disintegrating tablet matrix similar to Multiple Unit Pellet System (**MUPS**) tablets.

As particle size and shape would have a major impact on dissolution kinetics and potentially extent, we chose intrinsic dissolution testing as an area normalized characterization tool (Tseng et al., 2014). The IDR could be presumably affected by several different parameters such as preferred orientation, crystal habit, solubility, surface free energy (SFE) and crystal strains. A modified intrinsic dissolution apparatus was developed based on the rotating disk system (Wood's apparatus). This ensured the facilitation of the preparation and examination of IDR disks compacted under higher pressure.

Ibuprofen (IBU), as a borderline BCS II candidate, was used as a model compound. The existence of a crystalline metastable form of IBU was reported by Dudognon and colleagues 2008, however, the solubility and stability still needs to be addressed (Dudognon et al., 2008). Four excipients were used that included Hydroxypropylcellulose (HPC) and three sugar-alcohols, namely isomalt (ISO), mannitol (MANN) and sorbitol (SORB).

Certain effects can be induced via milling processes of pure ingredients on their own or the co-milling with a suitable adjuvant. Some examples of these effects, through which the drug dissolution and solubility could be improved (Loh et al., 2015), are summarized for the current used ingredients (Table 1).

**Table 1 Examples on the milling or co-milling effects of the studied ingredients obtained from the literature**

Ingredient	Adjuvant	observations	Ref.
Ibuprofen	-	reduction of the particle size to about 1/20 of the initial size, no chemical changes in the particles	(Rhee et al., 2006).
Ibuprofen	-	Micronization to $\sim 3 \mu\text{m}$ , increased surface area, no induced Amorphization or change in crystal form, no chemical decomposition	(Niwa, 2010)
Ibuprofen	kaolin	complete Amorphization of IBU	(Mallick et al., 2008)
Ibuprofen	HPC	a partial loss in crystallinity of IBU, enlarged surface area and increased wettability	(Talukder et al., 2011)
Ibuprofen	physical mixture containing HPC	changes in the IBU thermal properties that were related to some crystal modifications and higher intermolecular interactions	(Romero et al., 1993)
Sorbitol	-	a progressive polymorphic transformation upon increasing the milling time to the metastable crystalline form A	(Descamps et al., 2007)
Mannitol	-	polymorphic conversion to the metastable form $\alpha$ , which reverts toward the stable physical state of crystalline form $\beta$ after RT storage	(Descamps et al., 2007)

Hence, it is important to address whether the magnitude of mentioned changes can be achieved by applying the high-pressure compaction of the binary mixture independent of a prior co-milling step. The IDR test was considered as a primary parameter of evaluation and comparison of different compacts of IBU prepared with and without a previous co-milling process. Several factors and experimental parameters of the prepared compacts, including the degree of increase in the apparent solubility, the

change in IBU solid state and IBU/ excipient interactions, were investigated and correlated with drug release. These correlations were performed to understand the relationship between material properties and the compact performance.

## 2 Materials and methods

### 2.1 Materials

The following chemicals were obtained from commercial suppliers and used as received: ibuprofen was obtained from BASF AG (Ludwigshafen, Germany); super special-low viscosity Hydroxypropylcellulose **HPC SSL** and isomalt (GalenIQ 721 DC, agglomerated spherical isomalt) were provided by NIPPON SODA (Tokyo, Japan) and Beneo-Palatinit (Mannheim, Germany), respectively. Both mannitol (Pearlitol SD100, prepared by spray-drying of hydrogenated mannose solution) and sorbitol (Neosorb P20/60, coarse sorbitol crystals) were provided by Roquette (Lestrem, France).

### 2.2 Methods

#### 2.2.1 Preparations of tablets using high pressure 500MPa

Development batches of binary mixtures (IBU: excipient) were prepared with a drug load of 20% (

Table 2). The mixtures (**MIX**) were blended for 15 minutes in a Turbula T2A Mixer (W.A. Bachofen, Basel, Switzerland) at 70 rpm and further with magnesium stearate (0.5%) for additional one minute. Blends obtained were directly compressed on a single punch tablet press (FlexiTab, Röltgen GmbH & Co. KG, Solingen, Germany) using 10-mm round, flat face punches. Dwell time was set at 500 ms and the compaction force was fixed to reach a pressure of 500 MPa. Filling depth was adjusted to obtain 300 mg tablets.

Corresponding tablets were also prepared from mixtures as described previously, but using co-milled mixtures (oscillating ball mill Retsch MM 100, Haan, Germany). Milling was performed in 50ml stainless steel vessels and a grinding ball ( $\varnothing$  25 mm); at a frequency of 12 Hz for 20 min. The obtained tablets were subsequently broken (granulated) by an Erweka Dry Granulator AR402 (Heusenstamm, Germany) and passed through sieves but only the granules between 1.5 and 2 mm underwent further testing. Tablets (**Tab**) for testing of intrinsic dissolution and related granules (**Gr**) for aqueous solubility testing that have been prepared without milling, are referred to as standard compacts (**ST**), whereas the ones obtained from the milled blends are co-milled compacts (**COM**).

**Table 2 Composition of ibuprofen formulations**

Formulation	Composition (Wt%)	Milling before compression
IBU-HPC ST-Tab/-Gr	ibuprofen/ HPC SSL 20/80	No
IBU-HPC COM-Tab/-Gr	ibuprofen/ HPC SSL 20/80	Yes
IBU-ISO ST-Tab/-Gr	ibuprofen/ isomalt 20/80	No
IBU-ISO COM-Tab/-Gr	ibuprofen/ isomalt 20/80	Yes
IBU-MANN ST-Tab/-Gr	ibuprofen/ mannitol 20/80	No
IBU-MANN COM-Tab/-Gr	ibuprofen/ mannitol 20/80	Yes

IBU-SORB ST-Tab/-Gr	ibuprofen/ sorbitol	20/80	No
IBU-SORB COM-Tab/-Gr	ibuprofen/ sorbitol	20/80	Yes

### 2.2.2 Preparations of IDR tablets

In order to make non-disintegrating IDR-disks of pure IBU and other IBU/excipient mixtures feasible at high pressure, Flexi-Tab operation of compaction was adjusted and modified. Binary mixtures ( $100 \pm 0.5$  mg) could then be subjected to 500 MPa and compressed directly inside a special die (Figure 1) with known geometry and size ( $\varnothing=8$  mm). The die with the integrated disk was later coupled to the modified assembly of dissolution tester SOTAX AT7 (Basel, Switzerland) as described further (2.2.3) to ensure one flat surface exposed to release medium.

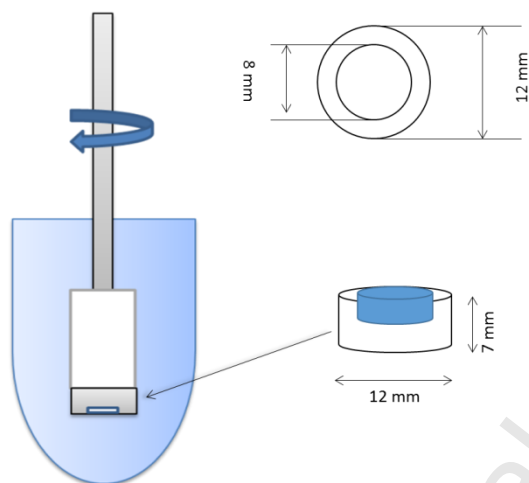

Figure 1 technical diagram of the new fabricated dies and die assembly for the IDR testing

### 2.2.3 Intrinsic dissolution procedure & analysis (Modified apparatus)

To enable the performance of IDR test for the above mentioned disks (2.2.2), a dissolution tester SOTAX AT7 (basket) was modified. The compact die assembly was built to suit the dissolution apparatus (Figure 1), considering the formal dimensions based on the description of rotating-disk system for IDR test (USP 40, test 1087).

IDR test was performed in hydrochloric acid (HCl) 0.1N (pH 1.0) and McIlvaine buffer 0.05 M (pH 5.5) in order to reflect the pH-dependent solubility of the weak acid. The pH-value of the prepared media was determined prior and at the end of the solubility/ dissolution tests, no pH-change ( $>0.05$ ) of the media was observed.

IDR analysis was carried out in triplicate at 100 rpm and  $37 \pm 0.5^\circ\text{C}$  in 900 ml of each medium.

For pH 1.0, samples were withdrawn automatically every 5 minutes and analyzed online using an Agilent 8453 UV-Vis Spectrophotometer (Agilent Technologies GmbH, Shanghai, China) at 220nm.

For pH 5.5, the samples were collected by an autosampler 850-DS Dissolution sampling station (Agilent Technologies, Waldbronn, Germany) at predetermined time intervals and analyzed by a Waters 2695 Separations Module HPLC system, equipped with a photodiode array detector (Waters 996). Separation was performed on a reverse-phase C18 column 5 $\mu\text{m}$  C18 100A, 150 x 4.6 mm (Inertsil 5 $\mu$  OS-3 100A).

The mobile phase consisted of 20 mM phosphate potassium pH 2.5: Acetonitrile (50:50 v/v). The eluent was monitored at 230 nm with a flow rate of 1 ml/min.

#### 2.2.4 Aqueous solubility at different pH values

Aqueous solubility determination of granules, related mixtures and plain IBU was executed by classical shake flask method in the same aqueous mediums used for the IDR test.

Saturated solutions were prepared by adding 50 ml of selected media into each flask which contained an excess quantity of drug. The sparingly soluble drugs need to be stirred or shaken for longer time to reach equilibrium (Baka et al., 2008). Hence, the solutions were shaken for seven days (Stuart and Box, 2005) under constant shaking rate of 50 agitations per minute and temperature ( $25 \pm 1^\circ\text{C}$ ) using a shaking bath (GFL 1083 Burgwedel, Germany). The solutions were then filtered using cellulose filters with 0.45 $\mu\text{m}$  pore size. The amount of dissolved IBU was determined in triplicate by an Agilent 8453 UV-Vis Spectrophotometer at 220 and 264 nm for pH 1.0 and pH 5.5 respectively.

#### 2.2.5 Solid state analysis

##### 2.2.5.1 X-Ray powder diffraction XRPD

Pure ingredients, tablets and correlating mixtures were evaluated using a Philips Expert pro MPD X-ray diffractometer (PANalytical, Almelo, Netherlands) at an accelerating voltage of 45 kV, a current of 40 mA and Ni-filtered radiation wavelength of  $\text{Cu K}\alpha = 0.154\text{ nm}$ . The analysis was performed in the range of 4 to 45  $^\circ 2\theta$ , with a step size of 0.0167  $^\circ 2\theta$  at 50.150 times per step and scan speed of 0.042  $^\circ 2\theta / \text{s}$ . The system was equipped with a  $2\theta$  compensating slit and automatic divergence slit. Stainless steel plates were used for reflection measurements as sample holders with an internal diameter of the ring of 16 mm and the thickness of 2.4 mm. The following settings were applied: continuous rotation as scan mode, sample length of 10 mm, irradiated length of 8 mm and the movement spinning enabled. The diffractograms were analyzed with X'Pert HighScore Plus software (version 2.2c, PANalytical, Almelo, Netherland).

##### Determination of crystallinity degree:

Crystallinity of IBU within IBU/HPC mixtures and tablets was quantified based on a linear relationship established between the sum of all diffracted peaks intensities (net areas) in the range of 5 to 45 Theta $^\circ$ . For calibration (supplementary data; **Error! Reference source not found.**) different amounts of the crystalline IBU were mixed with the corresponding amount of HPC in 50 ml high-density polyethylene bottles by a Turbula T2A Mixer at 70 rpm for 15 minutes and analyzed. The analysis was performed in triplicate for each IBU/ HPC ratio.

##### 2.2.5.2 Differential scanning calorimetry DSC

DSC analysis for individual ingredients, all mixtures and paired granules was done using a DSC2 METTLER TOLEDO (Mettler-Toledo GmbH, Gießen, Germany). 8-12mg samples were weighed into 40 $\mu\text{l}$  crucible aluminum-pans with pierced lid, subjected to a successive heating-cooling-heating cycle, with heating/cooling rates of 10 K/min and nitrogen as purge gas at 30 ml/min. Indium was used as standard for the calibration of the DSC module in the range of 120 to 180  $^\circ\text{C}$  with a heating rate of 10  $^\circ\text{C}/\text{min}$ , applying the following specifications: 27.45 to 29.45 J/g for the fusion enthalpy and 156.3 to 156.9  $^\circ\text{C}$  for the melting point.

### 2.2.6 Data analysis

Data were analyzed by one-way analysis of variance ANOVA, using OriginPro statistical package, to evaluate the differences within the formulations tested parameters. The differences were considered significant when p-value was lower than 0.05 (significant level). IDR values were obtained as the slope of the fitted line through the time intervals points for all compacts and compared by linear regression.

## 3 Results and Discussion

### 3.1 Intrinsic dissolution studies

All formulations tested exhibited a linear relationship between the cumulative amount (mg) of IBU released per  $\text{cm}^2$  and time ( $0.97 \leq r^2 \leq 0.998$ ; Figure 2). The IDR value was obtained from the slope of this relationship (Skinner, 2009). The period of a linear relationship over the entire test was 60 min for the acidic environment (Figure 2A). While, at pH 5.5 the dissolution at the surface of the IDR-disk was faster, hence the linear relationship between drug concentration and test time was reduced to 50 min (Figure 2B). The obtained linearity indicated that no superficial transformation into another polymorph of different solubility occurred (Issa and Ferraz, 2011). At the same time, the linearity proved the suitability of our modified intrinsic dissolution test.

All IBU-formulations showed statistically significant increased IDR compared with the crystalline IBU-disks in both media. This increase confirmed the importance of the presence of a hydrophilic excipient in the strategy proposed, whereas previous studies reported that the IDR of pure APIs was independent of the compression force applied (Iranloye and Ferratt, 1978; Yu et al., 2004).

Among the formulations tested, faster and hence, superior dissolution rates were obtained with HPC-compacts compared to the other excipients, followed by isomalt-compacts. ST-compacts with mannitol and sorbitol revealed the slowest IDR.

The differences between HPC-formulations and the other compacts, except IBU-ISO ST-Tab, were significant and very pronounced in the acidic medium. On the other hand, less differences could be noticed between HPC- and ISO-formulations at pH 5.5. ANOVA analysis showed that IBU-ISO ST-Tab differed significantly from other sugar-alcohols compacts in both media.

As expected, IDR values for the weak acid ibuprofen and formulations thereof increased for the pH 5.5 medium (Figure 2, Table 6) as compared to pH 1.0. IDR of IBU increased 5 to 36-fold and 5 to 88-fold at pH 1.0 and pH 5.5, respectively. The highest increase in IDR was observed for IBU-HPC COM-Tab. Sarode *et al.* similarly reported an increase of drug release for phenytoin upon ball-milling with HPC SSL that was even faster than a formulation prepared by hot melt mixing (Sarode et al., 2013).



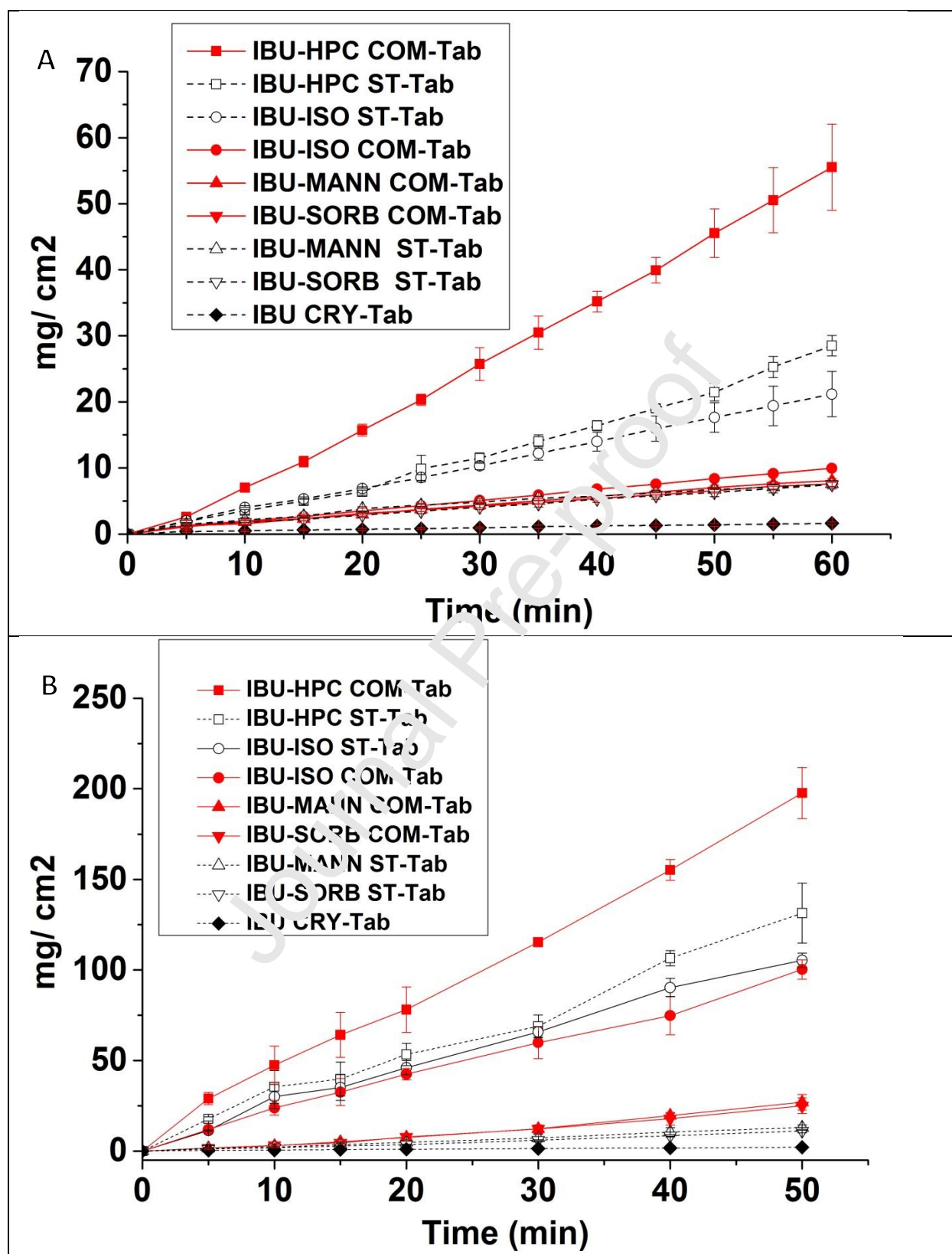

Figure 2 Intrinsic Dissolution profiles of ibuprofen formulations using modified USP apparatus 1 at 100 rpm; 37 °C, medium volume 900 ml of (A) pH 1.0; (B) pH 5.5; mean  $\pm$  SD; n = 3.

IDR of compacts prepared from co-milled mixtures was in general higher than that of related ST-Tabs. The higher strength of mechanical activation accompanied with the milling process could explain the enhanced dissolution rate of co-milled formulations. However, other than the co-milled tablets of IBU-HPC, no reduction in IBU crystallinity could be seen by the additional co-milling process as discussed later in 3.3.1. IBU-ISO ST-Tab was the only exception showing higher IDR than the co-milled counterpart IBU-ISO-COM-Tab with an increase of 14- and 49-fold at pH 1.0 and pH 5.5, respectively. Modi et al. (Modi et al., 2014) related this phenomenon to the decrease in the preferred orientation (degree of texture) of hydrophilic facets exposed on tablet the surface upon milling for the model drug celecoxib, leading to reduced wettability and IDR. Upon compression, the crystallites would strongly tend to be oriented more one way than all others with specific facets aligning preferably along the surface of the sample. Due to particle size reduction, a milling process allows the crystallites to be more randomly oriented (Modi et al., 2014; Tenho et al., 2007), which can reveal both hydrophobic and hydrophilic groups on the surface. The applied higher pressure compaction can impact the properties of crystal lattice surfaces and increase the preferred orientation and thereby depending on the functional groups that emerge at the crystal surface, the regarded surface will possess considerably different polarity (Bukovec et al., 2015). IBU-ISO ST-Tab might be characterized with higher texturization and more abundance of crystal planes that are rich with polar hydroxyl groups on the surface. As IBU-ISO ST-compacts showed more pronounced changes to their co-milled counterpart in XRPD analysis (see 3.3.1) such as higher intensity of peak at 20°, the preferred orientation of polar faces might have been the dominant impact on IDR and solubility for IBU-ISO compacts.

The relatively small increase in IDR of Mann and SORB ST-compacts could be related to less contribution of these additives to introduce high density of impurity defects and associated dislocations within the crystal lattice of IBU (Chan and Grant, 1987) as that obtained with ISO, and indicated later by XRPD and DSC analysis.

The considerable IDR increase observed with HPC compacts, correlated with the higher level of crystal modifications and IBU/HPC-interactions as discussed further in sections 3.3.1 and 3.3.2.

### 3.2 Solubility determination

The aqueous solubility ( $C_s$ ) of IBU out of our formulations after shaking for 7 days was improved by compaction in the range of 12 to 45 % at pH 1.0 and from 3 to 54 % at pH 5.5, compared to the aqueous solubility of neat, crystalline IBU (supplementary data, **Error! Reference source not found.**).

At pH 1.0 all excipients had a similar impact on increasing solubility for standard physical mixtures of about 10 % (Figure 3A). However, high pressure compaction of the standard mixtures increased the IBU aqueous solubility out of the compacted granules in the following order: HPC-Gr > ISO-Gr > MANN-Gr > SORB-Gr, where SORB showed practically no change upon compaction. Excluding ISO, all excipients showed even higher increase in solubility when co-milled materials were compacted at high pressure, maintaining the above-mentioned rank order.

At pH 5.5 (Figure 3B), the solubility-increase of formulations based on standard mixing was more pronounced for the granules form high pressure compaction with the exception of SORB, while the

solubility of the physical mixtures (PM) decreased compared to values in pH 1.0. Also, at pH 5.5 co-milling further increased the solubility with exception of ISO.

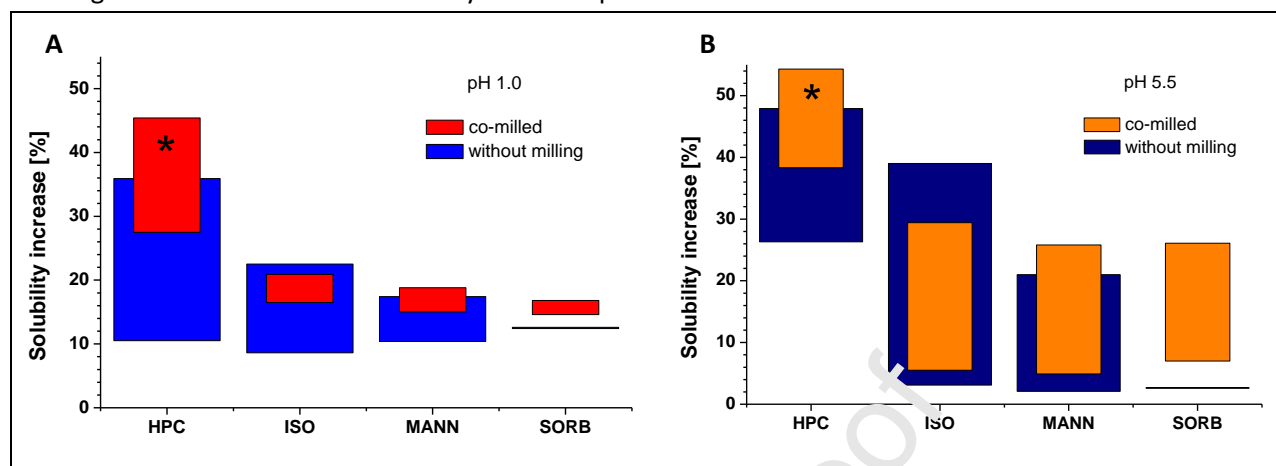

**Figure 3 Solubility increase [%] of IBU dependent on pH (A: pH 1.0; B: pH 5.5), two ingredients mixing conditions: without milling or co-milled. The bottom of the bars represents values for the physical mixtures; the top of the bars represents the granules obtained from high pressure compaction. \* partially amorphous (~ 38 %)**

For pH-dependent drugs, the extent of aqueous solubility is likely affected as the drug passes through the gastrointestinal tract (Douroumis and Fahr, 2011). The magnitude of solubility increase for the compacted formulations as compared to related mixtures was higher at pH 5.5 than at pH 1.0, except for HPC formulations, which might indicate higher influence of the applied process to improve solubility in medium where the IBU exists partially in ionized form. The same effect was observed from IDR test, confirming IDR importance for the examination of compaction process effect over the pH range of the gastrointestinal tract (Skinner and Karfer, 1992).

Similar to the presented IDR data, compacts with HPC and isomalt were superior to other excipients, with a particular advantage for IBU-HPC COM-Gr followed by IBU-HPC ST-Gr. Among the sugar-alcohols, only isomalt ST-formulations showed remarkable increase in the aqueous solubility and the closest to the HPC-Gr. Similarly, to the IDR test, an increase in  $C_s$  of IBU out of co-milled compacts as compared to ST-formulations in the both mediums was observed, IBU-ISO ST-granules were again the only exception.

**Table 3 Solubility factors of IBU formulations (physical mixtures PM, granules GR) and pure IBU**

Formulation	PM (pH 1.0)	Gr (pH 1.0)	PM (pH 5.5)	Gr (pH 5.5)
IBU-HPC ST	1.105	1.359	1.263	1.479
IBU-HPC COM	1.275	1.454	1.383	1.543
IBU-ISO ST	1.086	1.225	1.031	1.390
IBU-ISO COM	1.165	1.209	1.055	1.294
IBU-MANN ST	1.104	1.174	1.021	1.210
IBU-MANN COM	1.150	1.188	1.049	1.258
IBU-SORB ST	1.126	1.124	1.026	1.027
IBU-SORB COM	1.146	1.168	1.070	1.261

Interestingly, the formulations impact on the aqueous solubility measured after 7 days and the dynamic value of IDR measured during 60 min, led to the same rank order. Expressing the extent of solubility's increase of IBU out of the compacts as compared to neat IBU as solubility factor ( $C_{S,form}/C_{S,IBU}$ ; Table 3), and plotting it against the IDR, even revealed a linear relationship (Figure 4). In that respect, Yu *et al.* confirmed a good qualitative correlation between disk-IDR values and Biopharmaceutical Classification System BSC classes of solubility for 15 model drugs investigated (Yu et al., 2004). Furthermore, IDR testing was demonstrated to be a superior technique for solubility studies as compared to conventional equilibrium method (Dezani et al., 2013).

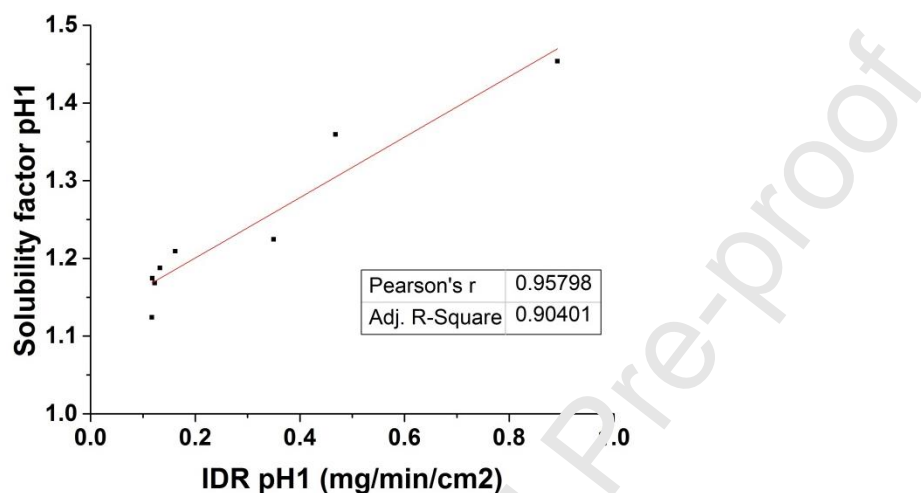

Figure 4 IDR correlation with solubility factor of the compacts at pH 1

### 3.3 Solid state analysis

#### 3.3.1 XRPD

The X-ray pattern of pure IBU and sugar-alcohols displayed numerous distinct peaks which referred to their crystalline nature. Pure HPC demonstrated experimentally a hollow pattern referring to a completely amorphous solid state (Otsuka et al., 2000; Speakman, n.d.).

In general, XRPD diffractograms (Figure 5, Figure 6) of all samples showed prominent peaks of IBU at specific  $2\theta$  values (16.5, 20 and 22°), conforming its crystalline nature (Nokhodchi et al., 2015). All peaks of the crystalline form were present in physical mixtures with lower intensity because of the dilution effect.

Various changes were observed of some IBU peaks in the diffraction pattern of the compacts when compared to the corresponding standard physical mixtures (**ST-MIX**). Hence, IBU in the tablets appeared to undergo some sort of crystal modification. However, the diffraction patterns and DSC thermograms of IBU induced within the compacts did not correspond to the metastable form of racemic ibuprofen identified by Dudognon and colleagues 2008. The recorded changes were most prominent for HPC ST-compacts, where the intensity of the peak at 22°  $2\theta$  increased and became sharper, whereas the intensity of other peaks at 16.5, 20, 28.5  $2\theta$  decreased (Figure 5). Additionally, other peaks almost disappeared at 14, 15, 34, 43° two theta; the one at 37° totally disappeared. Further, different peak

shapes at 16.5, 28.5  $2\theta$  were observed. The degree of changes was similar for ISO-compacts, where intensity and shape changes were observed at 16.5, 20, 22° and the loss of peaks at 19, 25, 34°  $2\theta$ . The MANN-compacts showed either reduced or increased intensities at 20, 34, and 36  $2\theta$ , and a change in the peak shape at 16.5°. Compacts with SORB exhibited the least changes, such as in peak shape at 16.5 and 20°  $2\theta$ .

The variation in the relative intensity of some characteristic peaks of ST-compacts, including small angles, could be attributed to either crystal size reduction or to crystal habit modification since the relative abundance of planes exposed to X-ray beam are different or could be related to the preferred orientation of certain crystallographic planes upon compaction (Flicker et al., 2012; Modi et al., 2014; Nokhodchi et al., 2015; Tenho et al., 2007).

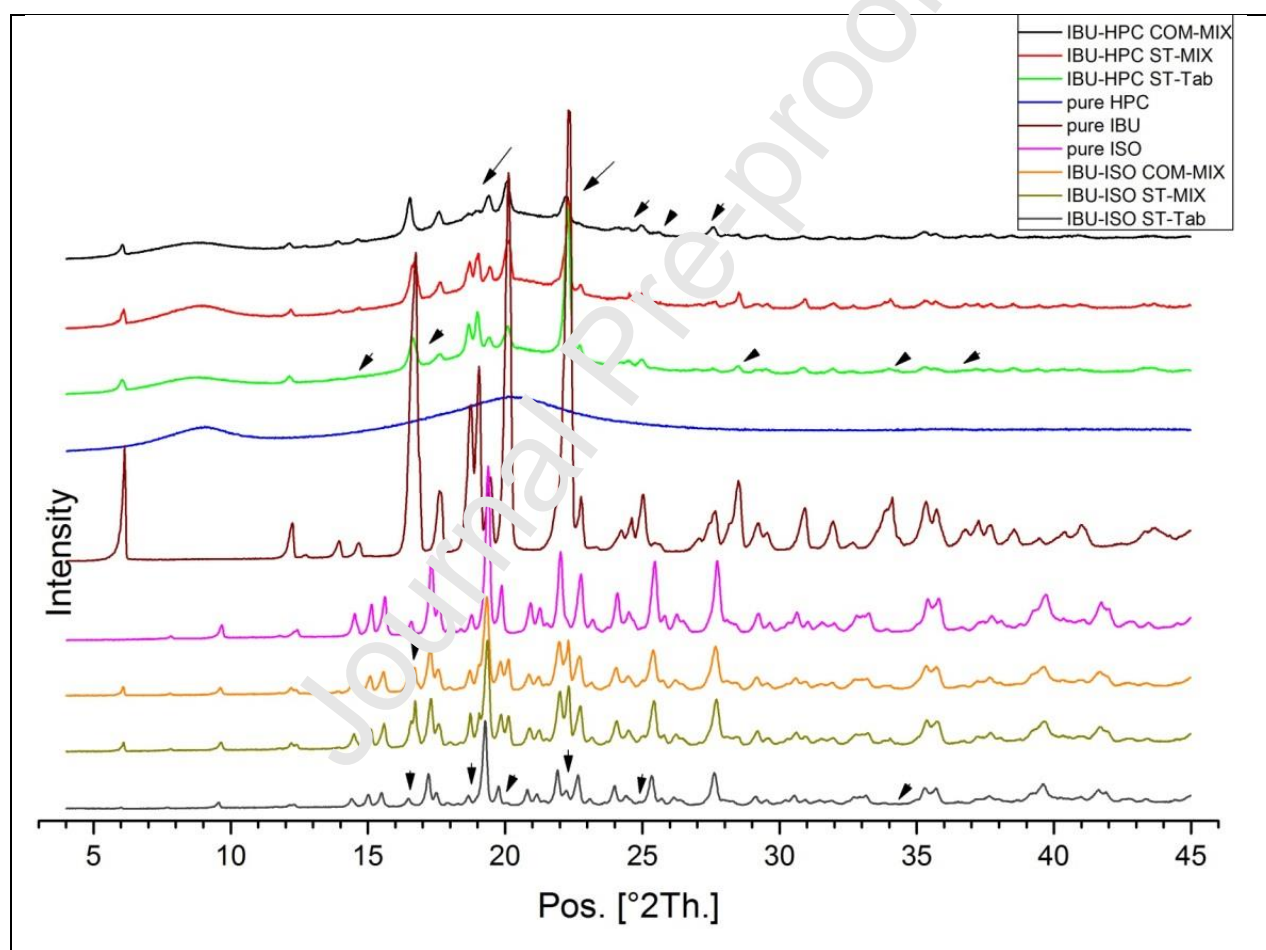

**Figure 5 X-ray Diffractogram of standard tablets and co-milled mixtures (COM-MIX) as compared to standard physical mixtures: IBU-HPC, IBU-ISO and the pure compounds, the arrows show the changes observed within the compacts and co-milled mixtures as compared to the corresponding physical mixtures**

The observed changes within XRPD of ST-compacts could be connected with different hydrophilicities i.e. molecular groups exposed on the surface and thus different ionization degree or with higher crystal energetics (i.e. defects and/or solvation (Chan and Grant, 1989)) as new forms of IBU were induced,

which can explain the higher IDR values obtained as compared to plain IBU. In this relation, the crystal habit modification can be enough to improve IDR (Bukovec et al., 2016). However, the presence of unchanged original IBU peaks suggested only partial modifications of the crystals, most likely on the surface. The differences in the observed changes between the ST-compacts can be an indication of variances in the facets on the surface that could be responsible for the different dissolution rates obtained.

Moreover, higher degrees of peak changes were even observed in relation to the co-milling process (Figure 5, Figure 6). In addition, the diffraction peaks broadened due to crystallite size reduction. The highest impact of the co-milling process was observed for HPC, resulting in a pronounced decrease in intensity of most peaks such at 18, 19, and 22° 2 $\theta$  due to the conversion of 38% of IBU into amorphous form (Table 4), different shape at 24, 27, and 28° 2 $\theta$ , disappeared peaks at 32.5 and 34° 2 $\theta$  and a new peak, which appeared at 25.5°. The co-milling impact was also evident with SORB and MANN resulting in different shape of some peaks and different intensities. The influence was less pronounced with ISO, which was reflected in the defect of peak shape at 16° 2 $\theta$  and in some differences in the intensities.

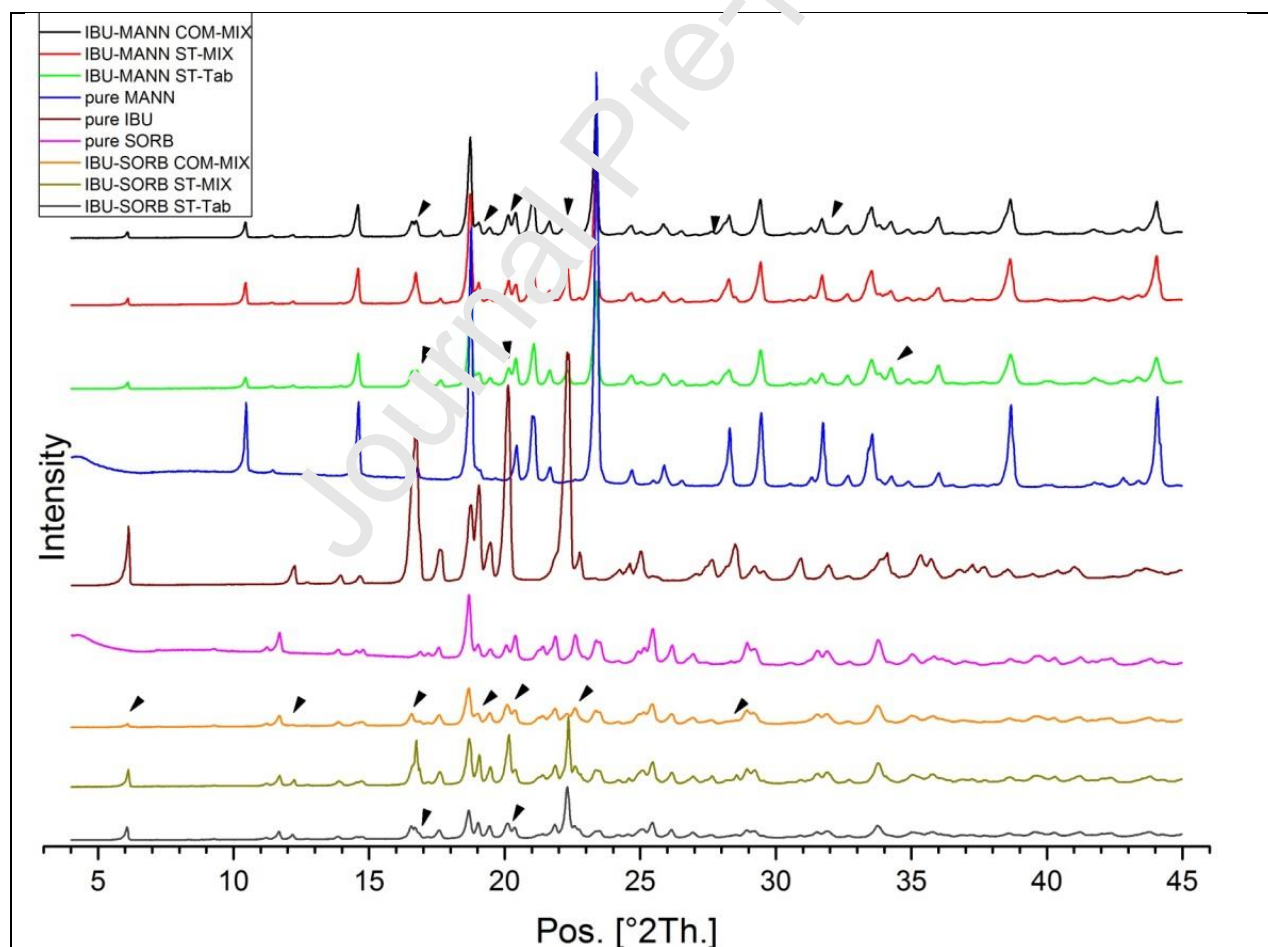

Figure 6 XRPD patterns of standard tablets and co-milled mixtures as compared to standard physical mixtures: IBU-MANN, IBU-SORB and the pure compounds.

Compaction after co-milling (supplementary data, **Error! Reference source not found.** and **Error! Reference source not found.**) produced additional changes in peak intensity of some peaks regarding ISO COM-compacts, in addition, there were minor changes in the peak shape at 16.5, 20 and 22° 2 $\theta$ . COM-compacts of MANN and SORB exhibited the same trend, with changed shape of peaks at 17, 20 2 $\theta$  and at 20° 2 $\theta$  respectively.

Considering that XRPD peak width correlates with material particle size (Barich et al., 2006), the diffractograms of COM-mixtures presented accordingly less sharp peaks as compared to their ST-mixtures. The absence of some IBU diffraction peaks in IBU-HPC COM-formulations as well as the appearance of more halo regions indicated the presence of IBU in amorphous form. Similar observations were reported by Talukder et al. (Talukder et al., 2011).

The partial loss in IBU crystallinity for the IBU-HPC co-milled formulations was confirmed by the calculation of the crystallinity (Table 4). However, there was no change in the IBU calculated crystallinity for IBU-HPC-ST tablets as well as the related physical mixture.

In spite of the difficulty encountered to employ XRPD to quantify the IBU crystallinity degree for sugar-alcohols compacts due to the crystalline nature of the used excipients (Barich et al., 2006), no indication could be observed of the presence of amorphous IBU within these compacts, suggesting no pronounced alternation of the overall crystallinity during compaction process or milling.

The induced amorphization for IBU-HPC COM-formulations most likely resulted from the dispersion of IBU molecules into the amorphous HPC. The physical stabilization of the resulting amorphous mixture and IBU/HPC-interactions may have a thermodynamic origin, where the IBU dispersed into HPC is below the solubility limit at room temperature at a 1:1 ratio IBU:HPC so that IBU and HPC form an amorphous molecular alloy at room temperature. This was indicated by the observation of no change in the amorphous content after 6 months of storage at ambient conditions.

As the compacts of co-milled IBU-HPC did not reveal significant variations in peak intensities and shapes when compared to the co-milled mixture, amorphization was mainly caused by co-milling and, to a rather negligible extent, by high pressure compaction.

**Table 4 Crystallinity determination of HPC SSL formulations**

Formulation	Sum of net intensity (cts)	Crystalline IBU %
IBU-HPC ST- MIX	1332606	100
IBU-HPC ST- Tab	1347465	100
IBU-HPC COM- MIX	811802	62
IBU-HPC COM- Tab	726002	55

Thus, the induced partial amorphization might be the main factor responsible for the obtained IDR improvement in case of IBU-HPC COM-Tab, whereas the higher induced energy, due to higher level of crystal defects and disorder, could describe the higher IDR and aqueous solubility of COM-Tabs of IBU-MANN and IBU-SORB as compared to their ST-compacts.

Overall, the magnitude of the changes, observed in XRPD as induced by high pressure compaction for ST-compacts was in the following rank order: IBU-HPC > IBU-ISO > IBU-MANN > IBU-SORB. This rank order is consistent with IDR data and confirms the employment of IDR test to have a better understanding of relationships between dissolution rate and the solid crystalline form. Depending on the excipient and the type of processing (with or without co-milling), high pressure compaction might be able to generate destabilization, rearrangement and fragilization of IBU intermolecular interactions and trigger new IBU/excipient-interactions, leading to changes in the arrangements between the molecules, i.e. packing polymorphism where the molecules possess quasi the same conformation (Brog et al., 2013).

### 3.3.2 DSC

Ibuprofen exhibited a sharp distinct melting onset at 75.64 °C. It also revealed a glass transition temperature (**T<sub>g</sub>**) at -46.3 °C. No melting point (**T<sub>m</sub>**) was found for neat HPC confirming the amorphous character of the polymer. Further, it revealed a T<sub>g</sub> of 28.3 °C. Neat isomalt, mannitol and sorbitol showed melting peaks at 161.6, 169 and 103.3 °C, respectively.

As compared to neat IBU, physical mixtures showed essentially similar melting onset around 75 °C; however, these were smaller due to sample dilution, except for HPC mixtures. IBU-HPC ST-MIX showed a sharp peak which corresponds to the melting endotherm of IBU shifted to lower temperature of 70 °C (onset), in addition to the measured T<sub>g</sub> around -4.8 °C. The co-milled mixtures showed a depression in the melting onset (Table 5).

DSC thermograms of all ST- and co-milled prepared compacts displayed IBU melting peaks indicating the presence of crystalline IBU.

However, some transformations of the solid form, even partially, could not be excluded. Some differences were noticed in T<sub>m</sub> of IBU for compacts as compared to their corresponding mixtures (Table 5, supplementary data; **Error! Reference source not found. - Error! Reference source not found.**). The melting endotherm was not as sharp as observed for related mixtures (particularly with HPC) and the onset of T<sub>m</sub> was reduced to a temperature range of 65.24 - 74.5 °C. The higher reduction of T<sub>m</sub> onset for IBU-HPC mixtures and tablets was probably related to the partial dissolution of IBU into the HPC matrix upon heating in DSC that could lead to an “eutectic impurity” of IBU. However, the T<sub>m</sub> onset for the tablets was still lower than the corresponding mixtures referring to higher IBU/HPC interactions within the tablets and to the effect of the process applied. ST- and COM-Tablets of IBU-HPC showed a glass transition in the first heating at -9.1 and -15.8 °C respectively.

The higher intermolecular hydrogen bonding between IBU and HPC in addition to the less mobility of IBU, as it was entrapped in polymer matrix upon milling, may be responsible for this conversion.

Statistically, all compacts showed a significant reduction of T<sub>m</sub> onset as compared to pure IBU (Table 6), except for MANN and SORB ST-Tabs. The T<sub>m</sub> onset depression of IBU was significantly higher for HPC ST and COM-compacts than other compacts.



**Table 5 The onset of IBU melting peaks for all compacts and corresponding mixtures by DSC measurement**

Sample	Melt onset temperature °C (MIX)	Melt onset temperature °C (Tab)
IBU-HPC ST	70.49 ± 0.89	65.24 ± 0.61
IBU-HPC COM	44.89 ± 0.18	43.99 ± 1.30
IBU-ISO ST	75.40 ± 0.09	74.01 ± 0.28
IBU-ISO COM	75.15 ± 0.09	73.90 ± 0.17
IBU-MANN ST	75.33 ± 0.51	74.50 ± 0.05
IBU-MANN COM	75.02 ± 0.03	72.91 ± 0.18
IBU-SORB ST	75.00 ± 0.28	74.37 ± 0.12
IBU-SORB COM	74.94 ± 0.01	73.28 ± 0.13
Pure IBU	75.64 ± 0.06	

The shift in melting point towards lower temperature might indicate the presence of new forms of IBU, and even more likely, suggest higher IBU/excipient interactions induced (Khodaverdi et al., 2012). This higher interaction would act similarly to an impurity showing fronting of the melt endotherm and subsequently earlier onset temperature. Romero *et al.* also reported changes in IBU thermal properties by tableting or grinding of physical mixture and were attributed to higher intermolecular interactions after compression (Romero et al., 1993).

The greatest melting point depression was particularly detected with HPC, whereby less strength of depression was connected to MANN and SORB ST-compacts. As an amorphous material with low T<sub>g</sub>, HPC possesses high molecular mobility and plasticity, which can cause API melting point depression. However, the rank order of the reduction in the melting onset for standard compacts was: IBU-HPC > IBU-ISO > IBU-MANN > IBU-SORB, which is in agreement with IDR data exhibiting the similar trend (Table 6). Co-milled formulations showed, in general, a lower melting onset compared to related ST-formulations referring to higher level of crystal defects or IBU/excipient interactions.

**Table 6 The reduction in the onset of *in vitro* for the compacts as compared to the related mixtures and pure IBU; the intrinsic dissolution rates of ibuprofen formulations and pure IBU**

Sample	Reduction in T <sub>m</sub> onset (°C) Tab /Mix	Reduction in T <sub>m</sub> onset (°C) Tab /pure IBU	IDR pH 1.0 mg/min/cm <sup>2</sup>	IDR pH 5.5 mg/min/cm <sup>2</sup>
IBU-HPC ST	5.25	10.40	0.468 ± 0.021	2.610 ± 0.230
IBU-HPC COM	0.90	31.65	0.892 ± 0.062	3.947 ± 0.079
IBU-ISO ST	1.39	1.63	0.350 ± 0.059	2.201 ± 0.117
IBU-ISO COM	1.25	1.74	0.162 ± 0.008	1.988 ± 0.157
IBU-MANN ST	0.83	1.14	0.118 ± 0.007	0.260 ± 0.037
IBU-MANN COM	2.11	2.73	0.133 ± 0.003	0.538 ± 0.070
IBU-SORB ST	0.63	1.27	0.117 ± 0.010	0.218 ± 0.016
IBU-SORB COM	1.66	2.36	0.123 ± 0.005	0.496 ± 0.088
IBU-CRY			0.025 ± 0.003	0.045 ± 0.001

As compared to the related mixture, IBU-HPC COM-compacts showed slightly higher values of change in heat capacity ( $\Delta C_p$ ) at  $T_g$  in the first heating cycle (0.3255 to 0.2997 Jg<sup>-1</sup>K<sup>-1</sup>), which can be explained by the higher fraction of amorphous IBU in the HPC-HPC COM-Tab (Lehto et al., 2006).

As compared to ST-mixtures, IBU-HPC ST-compacts showed lower values of  $T_g$  in the first heating run accompanied with higher  $\Delta C_p$  that might refer to higher interaction of IBU-HPC and thus higher depression of HPC  $T_g$ .

#### 4 Conclusion

High pressure compaction of IBU with polyols, namely isomalt, improved aqueous solubility and intrinsic dissolution rate significantly, without changing the crystalline state of IBU. In combination with the polymer HPC, the effect on aqueous solubility and dissolution was even more pronounced; however, with a high degree of IBU transformed into an amorphous state for the co-milled formulation. In general, the magnitude of increase in aqueous solubility and IDR was carrier-dependent and did not necessarily require co-milling of the binary mixture prior compaction.

The linearity obtained during IDR test confirmed the phase stability of the solid state of the compacts, i.e. no change in polymorphs occurred upon IDR testing. Besides, the enhanced solubility of IBU presented, based on the solubility determination data after shaking for 7 days, should provide a sufficient time for dissolved drug molecules to be absorbed under in vivo conditions.

The modified intrinsic dissolution apparatus was confirmed to be a feasible and reliable instrument to measure IDR of compacts prepared under high pressure. IDR test was verified as a primary parameter to assess drug dissolution properties and evaluate the impact of different solid forms on the product performance.

XRPD and DSC analysis suggests changes in the internal crystal structure of IBU, probably to a partial extent or in the external shape, or indicate increasing IBU/excipient interactions within the prepared compacts. XRPD and DSC findings were in line with the IDR results. Higher magnitude of changes was connected with higher IDR and aqueous solubility values.

Compacts from co-milled mixtures showed mostly higher degree of changes in XRPD as well as lower melting onset in the DSC than that of related ST-compacts referring to higher level of crystal defects. Hence, the high crystal energetics, associated with the co-milling process, could be the dominant effect on IDR in case of co-milled compacts.

As has been concluded from IDR and solubility values, higher impact of the process applied has been observed at  $pH > pK_a$  of IBU. Moreover, the overall effect of our approach has been to increase the dissolution rates rather than aqueous solubility, as compared to pure IBU.

The results of this work suggest screening high pressure compaction as a means to potentially improve aqueous solubility and IDR in a roller compaction process. The combination with co-milling of the substrates prior to compaction should be evaluated carefully, as milling did not always improve solubility and IDR performance of IBU and posed a higher likelihood to facilitate the formation of an (partially) amorphous drug.

### Acknowledgement

The authors would like to thank Franz-Josef Willems (technical Workshop, Pharmaceutical Institute, University of Bonn), Alexander Christen (Workshop for precision engineering, Institute of Physics University of Bonn), as well as the staff members of the glass workshop (Chemistry, University of Bonn) to manufacture the compact die assembly for the performance of IDR testing. We also would like to express our gratitude to KAAD (Catholic Academic Foreign Services) for supporting the scholarship programme. This research did not receive any specific grant from funding agencies in the public, commercial, or not-for-profit sectors.

### CRedit author statement

The following contributions were done by authors to the published work:

**Karl G. Wagner:** Conceptualization; Methodology; Supervision; Resources; review & editing. **Bashar**

**Ibraheem:** Conceptualization; Methodology; Investigation; Data curation; Writing - original draft

### Declaration of interests

The authors declare that they have no known competing financial interests or personal relationships that could have appeared to influence the work reported in this paper.

The authors declare the following financial interests/personal relationships which may be considered as potential competing interests:

### References

- Baka, E., Comer, J.E.A., Takács-Novak, K., 2008. Study of equilibrium solubility measurement by saturation shake-flask method using hydrochlorothiazide as model compound. *J. Pharm. Biomed. Anal.* 46, 325–341. doi:10.1016/j.jpba.2007.10.030
- Barich, D.H., Davis, J.M., Schieber, L.J., Zell, M.T., Munson, E.J., 2006. Investigation of Solid-State NMR Line Widths of Ibuprofen in Drug Formulations. *J. Pharm. Sci.* 95, 1586–1594. doi:10.1002/jps.20564
- Bindu MB, B, K., Banji, D., 2010. NOVEL STRATEGIES FOR POORLY WATER SOLUBLE DRUGS. *Int. J. Pharm. Sci. Rev. Res.* 4, 76–84.
- Brog, J.-P., Chanez, C.-L., Crochet, A., Fromm, K.M., 2013. Polymorphism, what it is and how to identify it: a systematic review. *RSC Adv.* 3, 16905. doi:10.1039/c3ra41559g
- Buckley, S.T., Frank, K.J., Fricker, G., Brandl, M., 2013. Biopharmaceutical classification of poorly soluble drugs with respect to “enabling formulations.” *Eur. J. Pharm. Sci.* 50, 8–16. doi:10.1016/j.ejps.2013.04.002
- Bukovec, P., Benkic, P., Smrkolj, M., Vrecer, F., 2016. Effect of crystal habit on the dissolution behaviour of simvastatin crystals and its relationship to crystallization solvent properties 263–268. doi:10.1691/ph.2016.5163

- Bukovec, P., Meden, A., Smrkolj, M., Vrečer, F., 2015. Influence of Crystal Habit on the Dissolution of Simvastatin Single Crystals. *Acta Chim. Slov.* 958–966. doi:10.17344/acsi.2015.1849
- Chan, H.-K., Grant, D.J.W., 1989. Influence of compaction on the intrinsic dissolution rate of modified acetaminophen and adipic acid crystals. *Int. J. Pharm.* 57, 117–124. doi:10.1016/0378-5173(89)90299-8
- Descamps, M., Willart, J.F., Dudognon, E., Caron, V., 2007. Transformation of Pharmaceutical Compounds upon Milling and Comilling: The Role of Tg. *J. Pharm. Sci.* 96, 1398–1407. doi:10.1002/jps.20939
- Dezani, A.B., Pereira, T.M., Caffaro, A.M., Reis, J.M., Serra, C.H. dos R., 2013. Equilibrium solubility versus intrinsic dissolution: characterization of lamivudine, stavudine and zidovudine for BCS classification. *Braz. J. Pharm. Sci.* 49, 853–863.
- Douroumis, D., Fahr, A. (Eds.), 2013. *Drug Delivery Strategies for Poorly Water-Soluble Drugs: Douroumis/Drug*. John Wiley & Sons Ltd, Oxford, UK. doi:10.1002/9781118444726
- Dudognon, E., Danède, F., Descamps, M., Correia, N.T., 2008. Evidence for a New Crystalline Phase of Racemic Ibuprofen. *Pharm. Res.* 25, 2853–2858. doi:10.1007/s11095-008-9655-7
- Fahr, A., Liu, X., 2007. Drug delivery strategies for poorly water-soluble drugs. *Expert Opin. Drug Deliv.* 4, 403–416. doi:10.1517/17425247.4.4.403
- Flicker, F., Eberle, V.A., Betz, G., 2012. Recrystallization of Commercial Carbamazepine Samples—A Strategy to Control Dissolution Variability. *Pharmaceutics* 4, 58–70. doi:10.3390/pharmaceutics4010058
- Iranloye, T.A., Parrott, E.L., 1978. Effects of Compression Force, Particle Size, and Lubricants on Dissolution Rate. *J. Pharm. Sci.* 67, 535–539. doi:10.1002/jps.2600670424
- Issa, M.G., Ferraz, H.G., 2011. Intrinsic Dissolution as a Tool for Evaluating Drug Solubility in Accordance with the Biopharmaceutics Classification System. *Dissolution Technol.* 18, 6–13. doi:10.14227/DT180311P6
- Khadka, P., Ro, J., Kim, Hyeongmin, Kim, I., Kim, J.T., Kim, Hyunil, Cho, J.M., Yun, G., Lee, J., 2014. Pharmaceutical particle technologies: An approach to improve drug solubility, dissolution and bioavailability. *Asian J. Pharm. Sci.* 9, 304–316. doi:10.1016/j.ajps.2014.05.005
- Khodaverdi, E., Khalili, N., Zangiabadi, F., Homayouni, A., 2012. Preparation, Characterization and Stability Studies of Glassy Solid Dispersions of Indomethacin using PVP and Isomalt as carriers. *Iran. J. Basic Med. Sci.* 15, 820–832.
- Lehto, V.-P., Tenho, M., Vähä-Meikkilä, K., Harjunen, P., Päällysaho, M., Väliisaari, J., Niemelä, P., Järvinen, K., 2006. The comparison of seven different methods to quantify the amorphous content of spray dried lactose. *Powder Technol.* 167, 85–93. doi:10.1016/j.powtec.2006.05.019
- Leuner, C., Dressman, J., 2000. Improving drug solubility for oral delivery using solid dispersions. *Eur. J. Pharm. Biopharm. Off. J. Arbeitsgemeinschaft Pharm. Verfahrenstechnik EV* 50, 47–60.
- Loh, Z.H., Samanta, A.K., Sia Heng, P.W., 2015. Overview of milling techniques for improving the solubility of poorly water-soluble drugs. *Asian J. Pharm. Sci.* 10, 255–274. doi:10.1016/j.ajps.2014.12.006
- Mallick, S., Pattnaik, S., Swain, K., De, P.K., Saha, A., Ghoshal, G., Mondal, A., 2008. Formation of physically stable amorphous phase of ibuprofen by solid state milling with kaolin. *Eur. J. Pharm. Biopharm.* 68, 346–351. doi:10.1016/j.ejpb.2007.06.003
- Modi, S.R., Dantuluri, A.K.R., Perumalla, S.R., Sun, C.C., Bansal, A.K., 2014. Effect of Crystal Habit on Intrinsic Dissolution Behavior of Celecoxib Due to Differential Wettability. *Cryst. Growth Des.* 14, 5283–5292. doi:10.1021/cg501084a
- Niwa, T., 2010. One-step preparation of pharmaceutical nanocrystals using ultra cryo-milling technique in liquid nitrogen. *Eur. J. Pharm. Sci.* 8.

- Nokhodchi, A., Homayouni, A., Araya, R., Kaialy, W., Obeidat, W., Asare-Addo, K., 2015. Crystal engineering of ibuprofen using starch derivatives in crystallization medium to produce promising ibuprofen with improved pharmaceutical performance. *RSC Adv.* 5, 46119–46131. doi:10.1039/C5RA06183K
- Otsuka, M., Kato, F., Matsuda, Y., 2000. Comparative evaluation of the degree of indomethacin crystallinity by chemoinformetrical fourier-transformed near-infrared spectroscopy and conventional powder X-ray diffractometry. *AAPS PharmSci* 2, 80–87. doi:10.1208/ps020109
- Pitt, K., Sinka, C., 2007. Chapter 16 Tableting, in: *Handbook of Powder Technology*. Elsevier, pp. 735–778. doi:10.1016/S0167-3785(07)80051-0
- Rasenack, N., Müller, B.W., 2005a. Poorly water-soluble drugs for oral delivery - A challenge for pharmaceutical development. Part II: Micronization technologies and complex formation. *Pharm. Ind.* 67, 447–451.
- Rasenack, N., Müller, B.W., 2005b. Poorly water-soluble drugs for oral delivery - A challenge for pharmaceutical development. Part III: Drug delivery systems containing the drug molecularly dispersed / Aspects on in vitro and in vivo characterization. *Pharm. Ind.* 67, 583–591.
- Rasenack, N., Müller, B.W., 2005c. Poorly water-soluble drugs for oral delivery - A challenge for pharmaceutical development. Part I: Physicochemical and biopharmaceutical background/strategies in pharmaceutical development. *Pharm. Ind.* 67, 323–326.
- Rhee, K.Y., Cho, H.K., Hong, J.S., 2006. An Investigation on the Application of Cryogenic Ball Milling to Ibuprofen Particle and Its Characteristics. *Mater. Sci. Forum* 505–507, 355–360. doi:10.4028/www.scientific.net/MSF.505-507.355
- Romero, A.J., Savastano, L., Rhodes, C.T., 1993. Monitoring crystal modifications in systems containing ibuprofen. *Int. J. Pharm.* 99, 125–134. doi:10.1016/0378-5173(93)90354-I
- Sarode, A., Wang, P., Cote, C., Worthen, D.R., 2013. Low-Viscosity Hydroxypropylcellulose (HPC) Grades SL and SSL: Versatile Pharmaceutical Polymers for Dissolution Enhancement, Controlled Release, and Pharmaceutical Processing. *AAPS PharmSciTech* 14, 151–159. doi:10.1208/s12249-012-9897-x
- Singh, A., Worku, Z.A., Van den Mooter, G., 2011. Oral formulation strategies to improve solubility of poorly water-soluble drugs. *Expert Opin. Drug Deliv.* 8, 1361–1378. doi:10.1517/17425247.2011.606808
- Sinka, I.C., Motazedian, F., Cocks, A.C.F., Pitt, K.G., 2009. The effect of processing parameters on pharmaceutical tablet properties. *Powder Technol.* 189, 276–284. doi:10.1016/j.powtec.2008.04.020
- Skinner, M., 2009. THE ROLE OF INTRINSIC DISSOLUTION RATE IN THE ASSESSMENT OF SOLID ORAL DOSAGE FORMS.
- Skinner, M., Kanfer, I., 1992. Intrinsic dissolution rate and solubility studies on josamycin, a macrolide antibiotic. *Int. J. Pharm.* 88, 151–158. doi:10.1016/0378-5173(92)90311-0
- Speakman, S.A., n.d. Introduction to X-Ray Powder Diffraction Data Analysis 25.
- Stuart, M., Box, K., 2005. Chasing Equilibrium: Measuring the Intrinsic Solubility of Weak Acids and Bases. *Anal. Chem.* 77, 983–990. doi:10.1021/ac048767n
- Talukder, R., Reed, C., Dürig, T., Hussain, M., 2011. Dissolution and Solid-State Characterization of Poorly Water-Soluble Drugs in the Presence of a Hydrophilic Carrier. *AAPS PharmSciTech* 12, 1227–1233. doi:10.1208/s12249-011-9697-8
- Tenho, M., Heinänen, P., Tanninen, V.P., Lehto, V.-P., 2007. Does the preferred orientation of crystallites in tablets affect the intrinsic dissolution? *J. Pharm. Biomed. Anal.* 43, 1315–1323. doi:10.1016/j.jpba.2006.10.038

- Thakkar, S., Sharma, K., Khurana, S., Bansal, A.K., 2016. Excipients and their Functionality for Enabling Technologies in Oral Dosage Forms, in: Koo, O.M.Y. (Ed.), *Pharmaceutical Excipients*. John Wiley & Sons, Inc., Hoboken, NJ, USA, pp. 97–143. doi:10.1002/9781118992432.ch3
- Tseng, Y.-C., Patel, M., Zhao, Y., 2014. Determination of Intrinsic Dissolution Rate Using Miniaturized Rotating and Stationary Disk Systems. *Dissolution Technol.* 21, 24–29. doi:10.14227/DT210214P24
- Vemula, V.R., Lagishetty, V., Lingala, S., 2010. Solubility enhancement techniques. *Int. J. Pharm. Sci. Rev. Res.* 5, 41–51.
- Yu, L.X., Carlin, A.S., Amidon, G.L., Hussain, A.S., 2004. Feasibility studies of utilizing disk intrinsic dissolution rate to classify drugs. *Int. J. Pharm.* 270, 221–227. doi:10.1016/j.ijpharm.2003.10.016
- Zecevic, D.E., Meier, R., Daniels, R., Wagner, K.-G., 2014. Site specific solubility improvement using solid dispersions of HPMC-AS/HPC SSL – Mixtures. *Eur. J. Pharm. Biopharm.* 87, 264–270. doi:10.1016/j.ejpb.2014.03.018